

LAVINIA E-PPN

DATA SHEET

Description

The HEINZMANN E-PPN system is an extension solution for full electronic control of injected fuel quantity and injection timing. The LAVINIA E-PPN system extends existing mechanical diesel fuel injection systems which are based on single pumps.

Main component of the system is the solenoid activated injection control valve. The unit is located in the high-pressure fuel line of diesel engines.

It provides precise speed/load dependent fuel injection timing for optimised combustion under all operating conditions.

Controlled by a HEINZMANN magnetic valve control (MVC) it offers the benefits of electronic fuel control such as mapped injection timing, cylinder balancing and limitation functions. The valve offers the option of single cylinder shut-off. In dual-fuel applications the E-PPN valve enables independent speed/load ignition timing.

The system can easily be installed on most types of diesel engines with conventional single pump configuration.

Application range

- ➔ Diesel engines with mechanical injection systems based on single pumps
- ➔ Extension for dual-fuel conversion of diesel engines



Features

Speed/load dependent injection timing

Perfect cylinder to cylinder balancing

Ideal for dual-fuel converted engines, offers best conversion ratios and efficiency

For retrofit or new engines

Double-walled piping version for marine application available

Dimensions

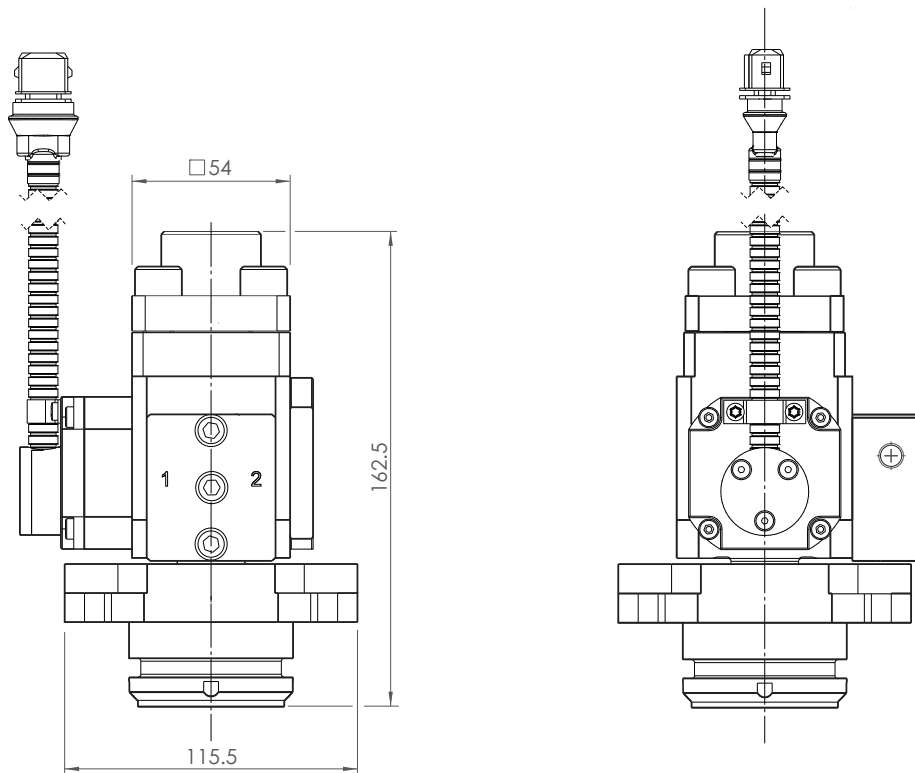

Example of E-PPN for direct mounting on unit pump

Technical data

Max. cylinder output	350 kW/cyl. (enhanced versions optional)
Max. system pressure	1600 bar
Fuel qualities	Diesel, MDO
Supply voltage	24 ... 90 V
Weight	2.8 kg (excluding adapters)

Subject to alterations. ©HEINZMANN GmbH & Co. KG, 2018